

MACHINE SPECIFICATION

BAG SQUEEZER SCT650



Machine name	SCT650	Manufacturer	Fluidor Equipment B.V.
Publication date	06-05-2024	Address	Ramgatseweg 25, 4941VN Raamsdonksveer, The Netherlands
Version	0.2	Telephone	+31(0)162 581 450

DESCRIPTION

Designed to squeeze emptied poly liners with product to reduce product loss to a bare minimum (< 0,1 %). Infeed and outfeed of poly liners by operator for this stand-alone machine.

Machine is equipped with a collecting tray with outlet at one side. Directly underneath this outlet an open drum can be placed to collect the product. Squeezer covers protected by safety switched and can be opened after production for easy cleaning.

DESIGN SPECIFICATION

- According actual CE-regulations
- Developed and build according quality system ISO 9001
- Clean design according actual EN1672-2 and HACCP-regulations
- Food contact materials according EC 1935/2004 and FDA
- Good Manufacturing Practice Regulation (EC) 2023/2006
- Components according Fluidor standard components list
- Machine control by push buttons on the control cabinet
- Control cabinet IP55 / NEMA 12 (VX25.....,various sizes, AISI 304)
- Construction + product parts AISI304
- Hygienic stainless steel hopper with a height of 1200 mm
- Electric driven bag squeezer with finger protection, hygienic design, consisting out of knurled AISI 316 lower roller and natural rubber upper roller, assembled in 2 AISI316-side plates with lifetime lubricated closed bearings, IP66 electric drive without cooling fan
- Product loss < 0,1%, with foot operated reverse drive for safe operation
- Machine is designed to be used 12 hours a day 5 days a week and 52weeks a year with proper maintenance and an expected service life of 20 years



REQUIREMENTS

- Layout (dimensional, utility & requirements drawing) available upon request
- Earthquake area extra fixation needed (Anchors option)
- Machine is designed for indoor use in a medium hygiene wet area

TECHNICAL DATA

	EU	USA
· Total weight empty	: 260 kg	573 lbs
· Total weight Full	: 308 kg	680 lbs
· Product / CIP temp	: -20, +90 °C max 60 minutes	-4, 194 °F max 60 minutes
· Ambient temperature	: 5 - 25 °C	41 - 77 °F
· Relative humidity	: 30 - 70%	
· Noise level	: < 85 dB(A)	
· IP value (control cabinets + drives)	: IP55	
· Product hopper volume	: 48 L	12,5 gal
· Adjustable machine support legs	: 80 -160 mm	3.15 - 6.3 inch
· Dimensions h*w*d:	: 1750*1160*940mm	69*46*37 inch
· Installed power	: 1 kW	1,36 HP

CAPACITY

- Depending on poly liner, product & operator: capacity approx. 60 liners per hour

PRODUCT INFORMATION

- Product type : Fruit juices and concentrates, liquid
- Product viscosity max : Dynamic viscosity 20.000 cP

CLEANING

- Cleaning depends on the product and company guidelines
- Manual cleaning after each production batch or before each production run after 12 hours of downtime
- Manual cleaning +/- 10 min

POLY LINER SPECIFICATION

	EU	USA
· Poly liners:	10 to 200 Liters	2,7 to 52 gal
· maximum liner width	1000 mm	39" inches

MACHINE EXECUTIONS

- One standard execution

POWER SUPPLY / CONTROLES

- 3 Phase 400V 50Hz 5 A+ neutral + earth, Siemens controls
- 3 Phase 480V 60Hz 4 A + earth, Allen-Bradley controls, UL prepared

OPTIONS

- HD control cabinet: IP66/IP X9 / NEMA 13/NEMA 4X (HD....., AISI 304)

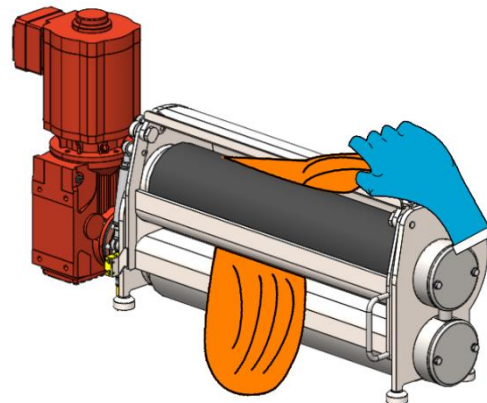
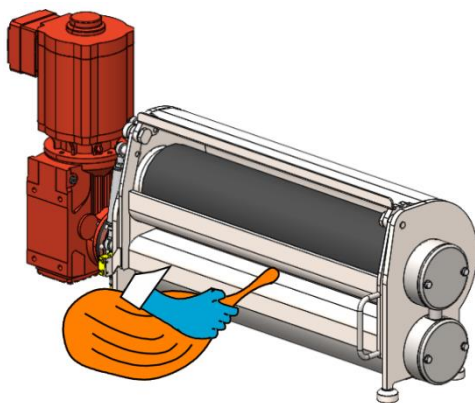

ANNEXED DOCUMENTS

- Machine Lay-out
- Machine P&ID
- Fluidor standard components

GENERAL INFORMATION

Website	: www.fluidor.com
Telephone	: +31 162 581450
Sales	: Mr. Jan Vermeulen
Telephone:	: +31 162 581457
Mobile	: +31 6 25009609
Email	: j.vermeulen@Fluidor.com
Spares	: Mr. Wing Ho Kwok
Telephone	: +31 162 581468
Email	: wh.kwok@fluidor.com
Service	: Service department
Telephone	: +31 162 581466
Email	: service@fluidor.com